

# Fiberoptic IEEE C37.94 - G.703 E1 mux 21-219



# Technical manual

# About this manual

---

## About the contents of this manual

The information in this document may be changed at any time without notice.

## Table of Contents

About the contents of this manual	2	Product 21-219 consists of:	10
Table of Contents	2	Serial number.	11
Version and revision history.	3	Front Panel.	11
Revision history for product:	3	Back Panel.	11
Revision history for this document.	3	BNC 75 Ohm G.703 E1 Port	12
Functional	4	Fiber Optic IEEE C37.94 Ports.	13
IEEE C37.94	4	Functional earth/ground, FE.	13
G.703 E1 2048kbit/s	5	Normal use	14
Applications	6	Config rotary switch	14
Features	8	External clock	15
Fiberoptic and data transfer protocol	8	Internal clock - "Master mode"	15
G.703 - E1	8	Power on.	16
Power Supply.	8	LED-status.	16
Environmental conditions	8	CE - mark	18
CE compliance	8		
Mechanical	8		
EMC compliance	8		
Insulation	9		
Physical size and Weight	9		
Unpacking.	10		

---

## Version and revision history.

Revision history for product:

Revision R0.

Product released for serial production. 2006-05-26.

Revision history for this document.

Revision AK0.

2006-05-30, AnNy, document created.

Revision R0.

2006-06-05, AnNy, document released.

### **Document properties.**

Last saved: 6/5/2006 3:42:00 PM

Filename: Technical Manual 90\_20\_0113R0

### **Author.**

Created by Anders Nyström.

Last saved by Anders Nyström.

# General description

## Functional

The 21-219, Fiberoptic IEEE C37.94 - G.703 E1 converter is intended to extend distance and galvanic isolate the teleprotection equipment for substations connection to telecom network.

IEEE C37.94

The standard “IEEE C37.94-2002, IEEE Standard for N times 64 Kilobit per Second Optical Fiber Interfaces between Teleprotection and Multiplexer Equipment” describes a fiberoptic intra-substation communication links between teleprotection equipment and multiplexers.

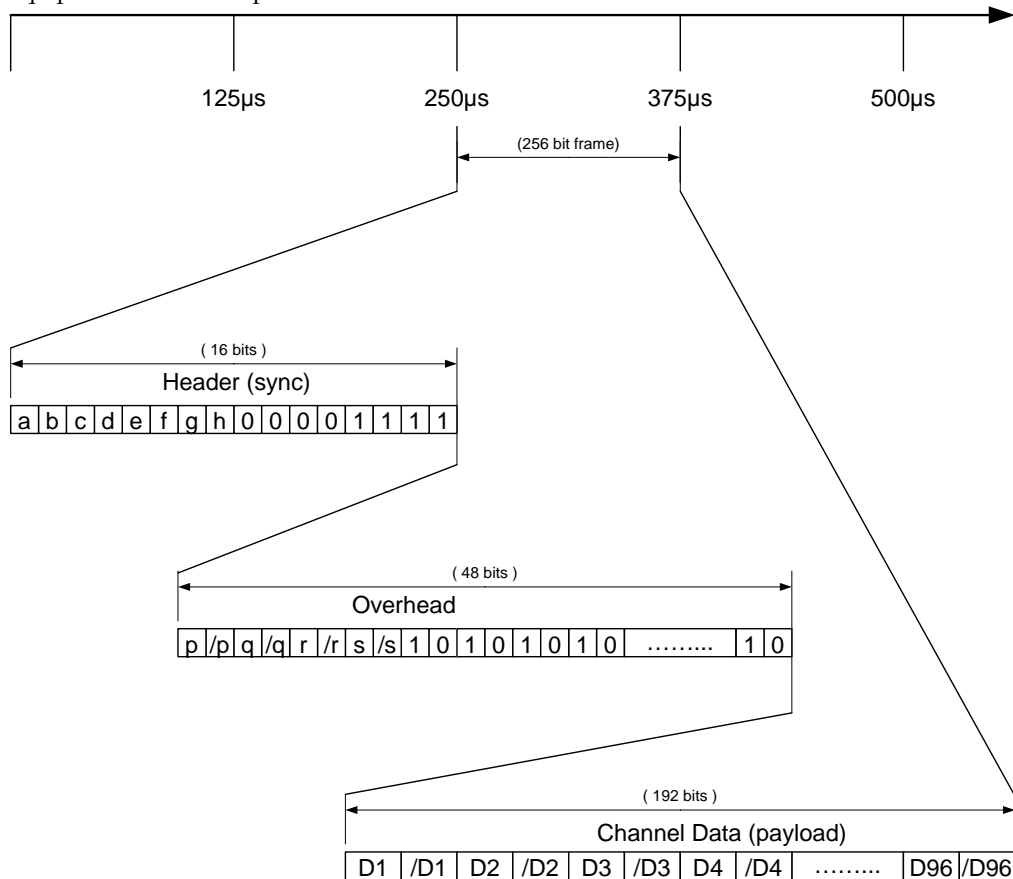

The bit c in “Header” is used for “Yellow Alarm”. (Every other frame).  
 Bits p,q,r and s in “Overhead” form a HEX-value indicating the number of timeslots used for data.

0.0.0.1 for N=1

0.0.1.0 for N=2

....

1.1.0.0 for N=12, (0CH).

12 timeslots, (1 timeslot has 8bits → 12x8bits=96bits. With complement bits → 2x96=192 bits). Data bits in not used timeslots are set to 1.

G.703 E1 2048kbit/s

The G.703, E1, 2048kbit/s unbalanced, (75 Ohm BNC), ports are intended to connect to, for example, a leased telecom line.

21-219

There are two C37.94 fiber optic ports that are multiplexed into one E1-protocol.

“Channel 0” is inserted/extracted in timeslot 1 – 13 in the E1-protocol.

“Channel 1” is inserted/extracted in timeslot 17 – 29 in the E1-protocol.

E1 timeslot 0 contains framing/synchronization information. Timeslots 14, 15, 16, 30 and 31 are ignored at receive and set to 0 at transmit.

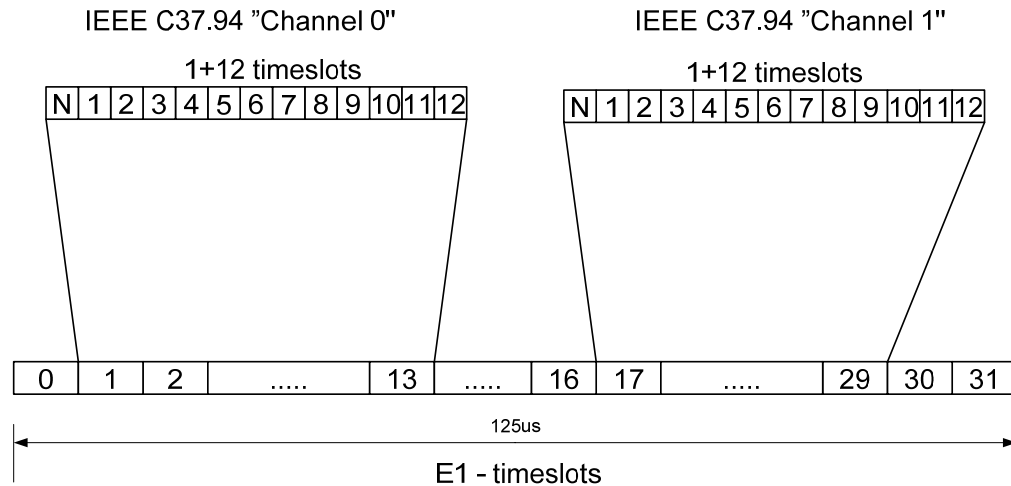

In the IEEE C37.94 protocol each data bit is followed by its complement. Only “true”, (non complement), data bits are transferred to E1-protocol.

The N is fetched from the IEEE C97.94 protocol indicating the number of timeslots used in the protocol.

The 21-219 transfer the N-value but don't use it for any other purpose.

All data bits in all 12 timeslots are transferred, regardless of the value of N.

Applications

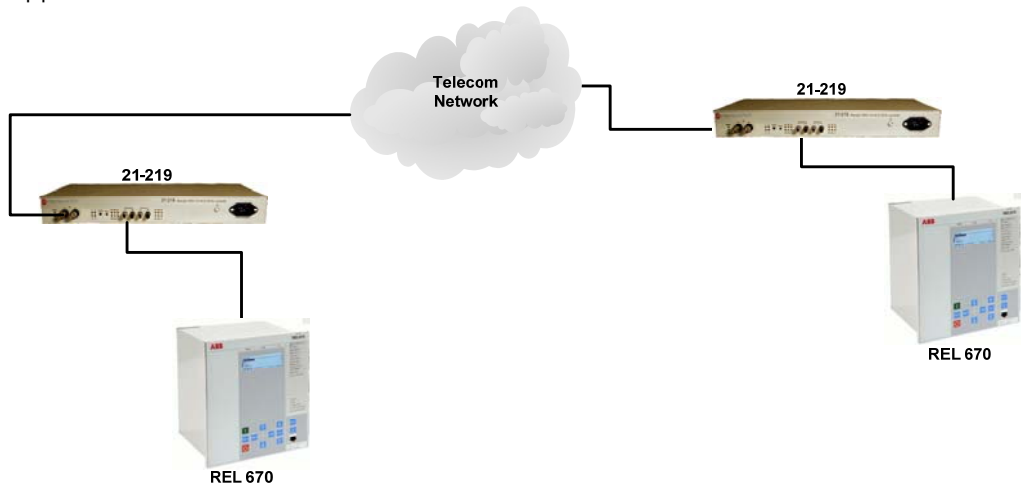

*Singel IEEE C37.94 link via Telecom network.*

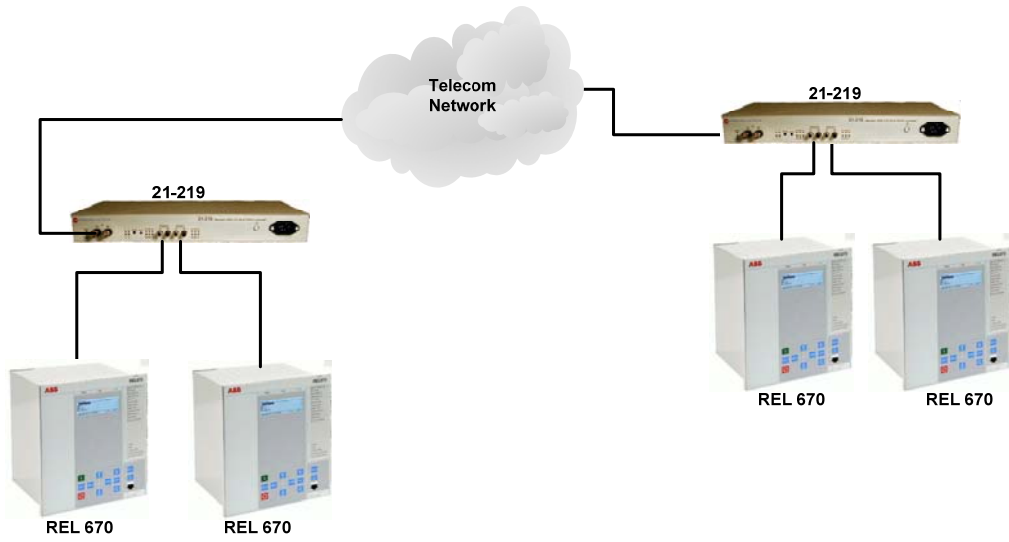

*Dual IEEE C37.94 link via Telecom network.*

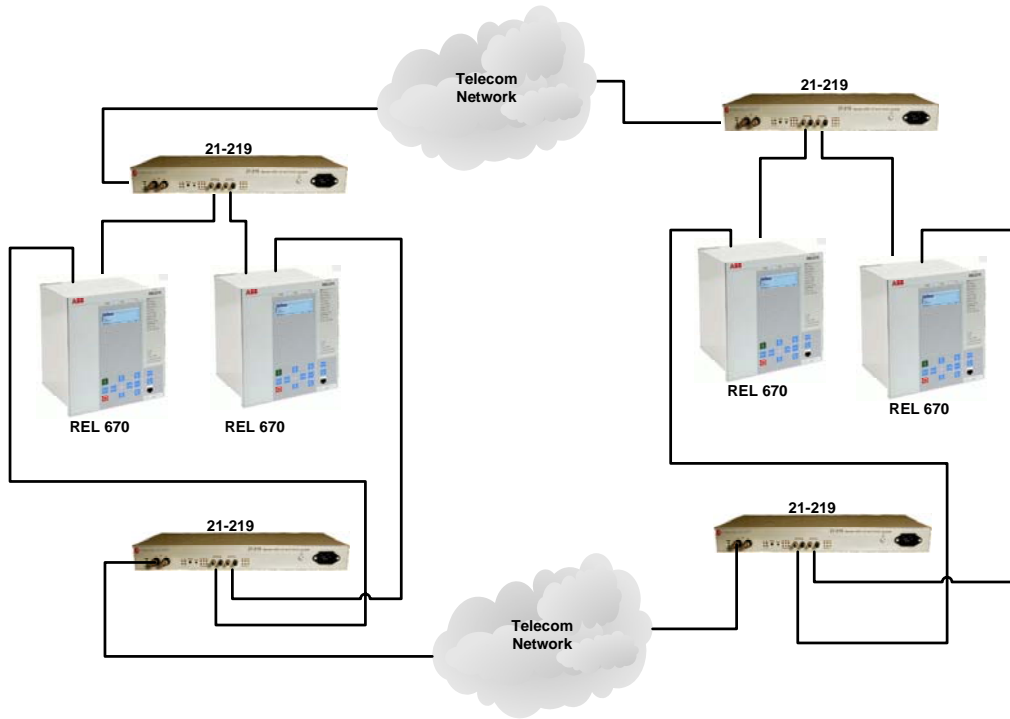

*Redundant REL 670 system.*

## Features

Fiber optic and data transfer protocol  
Data speed

2.048Mbit/s, IEEE C37.94 protocol.

### Optical data

Wavelength  
Fiber optical connector  
Optical System budget

820nm  
ST  
13dB with multimode fiber,  
(62.5/125  $\mu$ m)  
9dB with multimode fiber,  
(50/125  $\mu$ m)

Typical distance

2km (6dB systemmargin for 62.5/125  
and 3dB margin for 50/125).

G.703 – E1

Interface  
Protocol

2 BNCs, unbalanced 75 Ohm.  
G.703, G.704, 2048 kbit/s. PCM31 or  
PCM31C, (CRC-check is not used by  
21-219).

Power Supply.

48V DC to 250V DC,  $\pm$  20%  
110V AC to 230V AC, 50Hz,  $\pm$  20%.  
AC connector IEC 320, 3 pin.  
Power consumption <20W.

OBS! The IEC320 standard plug has ground earth  
on the middle pin. When using DC, negative and  
positive polarity works both ways.

Environmental conditions

Operating temperature range  
Storage temperature range  
Relative humidity operating  
Relative humidity storage

-25 to +70 °C.  
-40 to +85 °C.  
5 to 95%.  
5 to 95% non condensing.

CE compliance

Immunity  
Emission

EN 61000-6-2  
EN 61000-6-4  
EN 50178, RIV = 250V OVC = III

LVD

Mechanical

Vibration

IEC 60255-21-1 Class 2

Shock

IEC 60255-21-2 Class 2

Sismic

IEC 60255-21-3 Class 2

EMC compliance

ESD

IEC 60255-22-2 Class 3, contact 6kV, air 8kV.

Radiated

IEC 60255-22-3 / IEEE/ANSI C37.90.2; 35V/m

Burst Power

IEC 60255-22-1 Class III

Burst Communication

IEC 60255-22-1 Class II; 0,5kV diff, 1kV common mode

Fast transient Power

IEC 60255-22-4 Class IV

Fast transient Communication

IEC 60255-22-4 Class II; 1kV

Insulation	
Dielectric test	IEC 60-255-5, 2,0kV 1min
Impulse voltage test	IEC 60255 / EN 50178 5kV / 6kV
Insulation resistance	IEC 60255-5; >100MΩ at 500VDC

#### Physical size and Weight

The unit can be mounted in a 19" rack.

By adjusting, the rack mount brackets, the unit can also be mounted on a wall or similar.

Height	45 mm
Width	483 mm (380 mm without rack mount brackets).
Depth	173 mm (from front to back, connectors excluded).
Weight	3 kg

## Unpacking.

Check that the packing material has no damage. If damages are discovered on packing material, contact your shipping company, before unpacking.

The delivered product consists of several parts. Check that all parts are present according to the list below, and have no damage.

Product 21-219 consists of:

	Quantity	Part number	Description
1	1	21-219	Fo IEEE C37.94-G.703 E1 mux <i>(Part number includes all parts in this list).</i>
2	2	60-00-5387	Rack Mounting Bracket
3	8	50-65-1673	Screw, MFX-H M3x5 FZB
4	1	50-65-0106	Power cord, 1.8m European connector.
5	4	50-65-5030	Rubber feet
6	1	90-20-0113	This manual



21-219, *(Part number includes all parts in list above).*

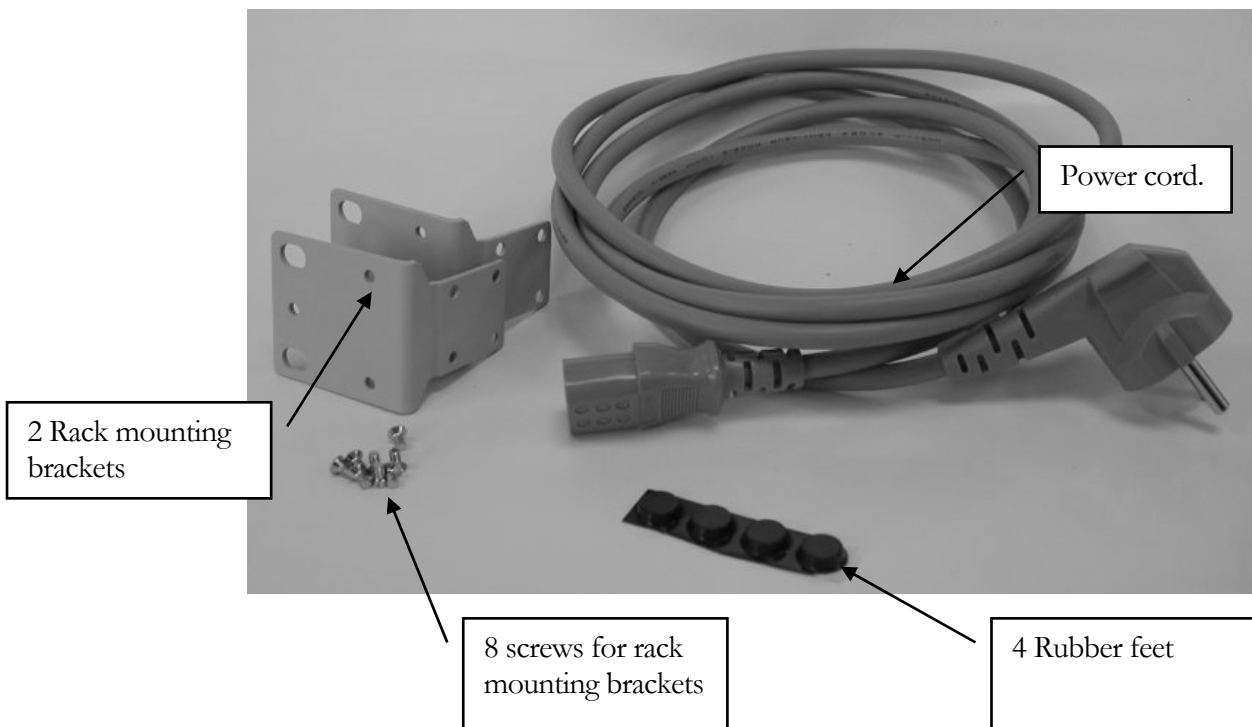

# Installation.

Serial number.

The products serial number is the best way for Fibersystem to identify the product. If the serial number is not noted on your delivery notes, please add the serial number to your own product documentation. This will be useful at future contact with Fibersystem.

Front Panel.

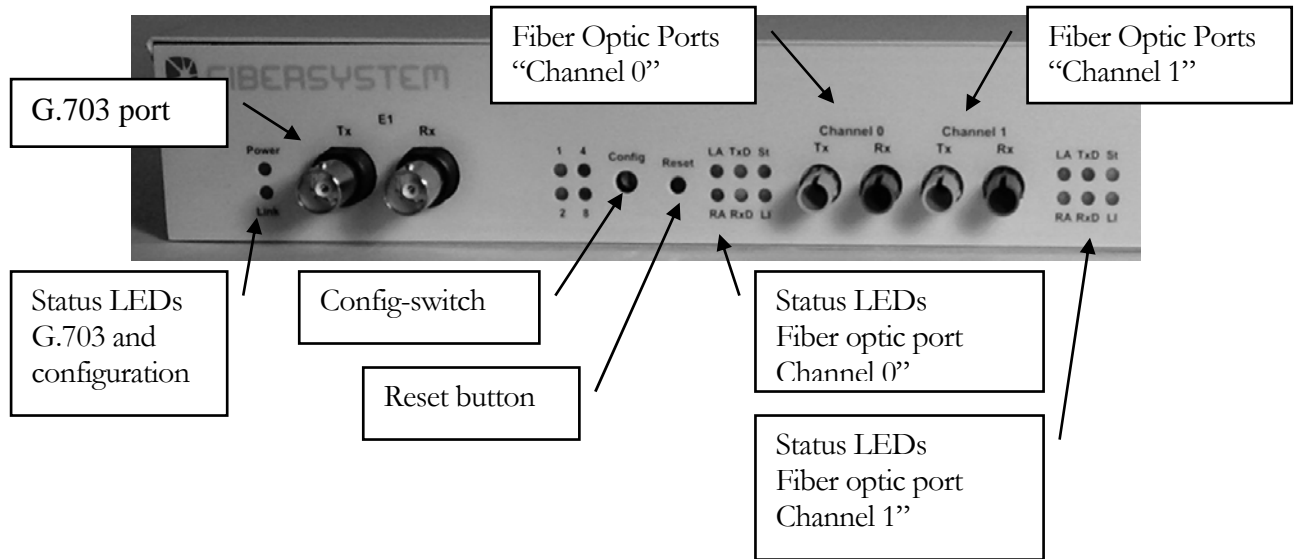
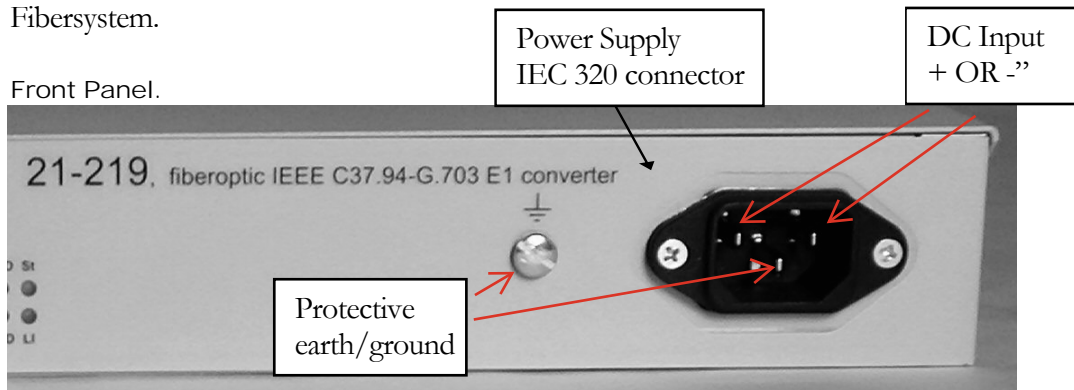

Back Panel.

There are no connections or indications on the back panel.

## Mounting

The products can be used stand alone, rack mounted or attached with screws to wall or similar.

The rack brackets have two alternative places on each side of the unit and the brackets can be rotated for alternative positions.

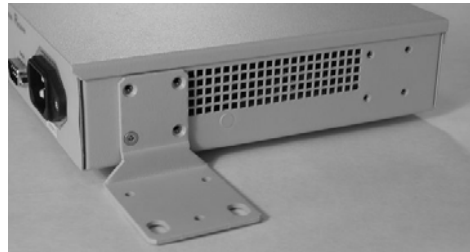
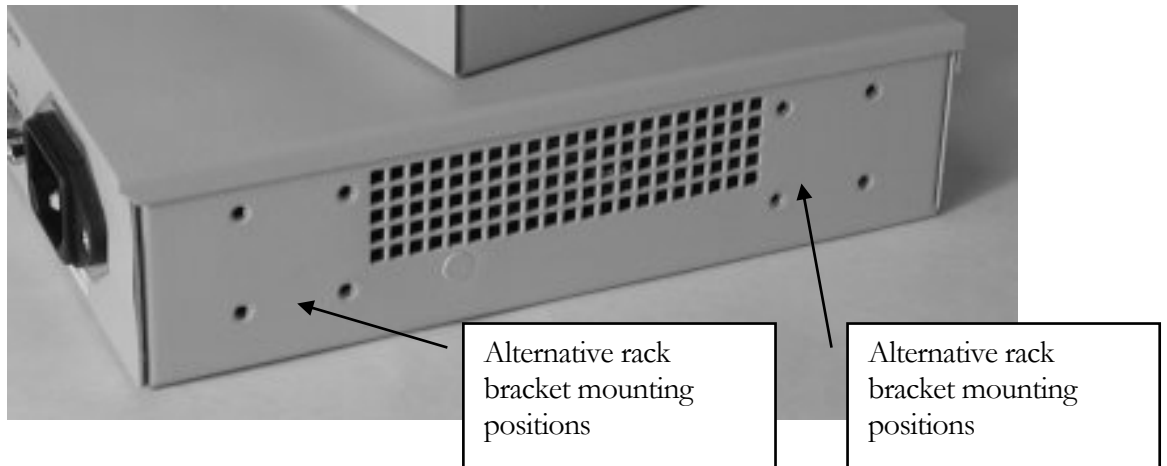

## BNC 75 Ohm G.703 E1 Port

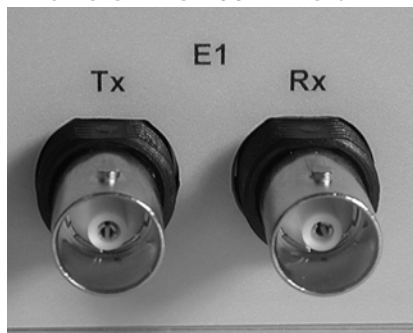

The connectors are BNC. Tx-port sends data out from 21-219, Rx-port receives data. The BNC-shield is internally connected to chassis/FE.

For best signal integrity use a high quality double shielded coaxial cable. For example RG216.

Fiber Optic IEEE C37.94 Ports.

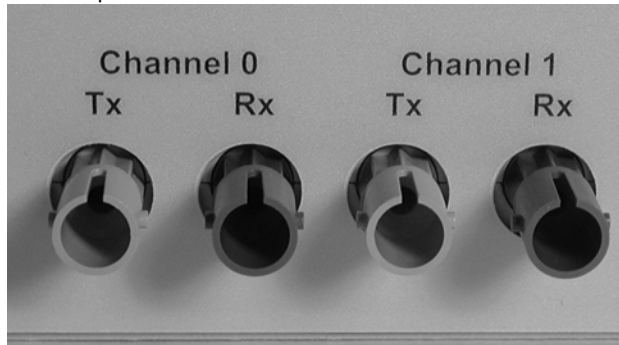

The fiber optic connector is of ST type.

Confirm that the attenuation of the fiber optic cable, including splices and patch cables, doesn't exceed the system budget. Don't forget to add a safety margin. Minimum safety margin is 3dB.

Make sure that the local fiber optic transmitter, marked Tx, is connected to the remote units fiber optic receiver, marked Rx. And local Rx shall be connected to remote Tx.

Functional earth/ground, FE.



To the left of the IEC 320 power supply connector, a reference ground/earth screw is available.

Protective earth/ground, PE, shall be connected to the IEC 320 power supply connector.

# Configuration

Normal use

Normally no configuration is needed!

When two 21-219 are connected back-to-back, (E1 ports connected to each other), one of the 21-219 should be set to “Master mode”.

Config rotary switch

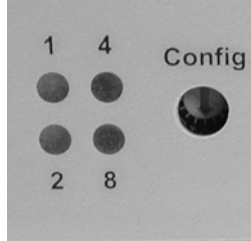

The rotary switch has 16 positions, (HEX-switch).

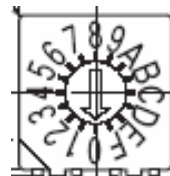

At position 0 the switch’s arrow, visible through the adjusting hole, points straight down.

All configuration is done by setting the position of the “Config” rotary switch on the frontpanel. The “Config”-switch is operated with a small screwdriver. The switch has 16 positions. Every switch position is presented by the four LEDs 1, 2, 4 and 8. The LEDs forms a corresponding binary-value of the switch position. In the table below an “X” marks a lit LED.

LED 1	LED 2	LED 4	LED 8	FUNCTION
				(0H) External clock selected. “Slave mode”
X				(1H) Internal clock selected. “Master mode”
	X			(2H) <i>Future use</i>
X	X			(3H) <i>Future use</i>
		X		(4H) <i>Future use</i>
X		X		(5H) <i>Future use</i>
	X	X		(6H) <i>Future use</i>
X	X	X		(7H) <i>Future use</i>
			X	(8H) <i>Future use</i>
X			X	(9H) <i>Future use</i>
	X		X	(AH) <i>Future use</i>
X	X		X	(BH) <i>Future use</i>
		X	X	(CH) <i>Future use</i>
X		X	X	(DH) <i>Future use</i>
	X	X	X	(EH) <i>Future use</i>
X	X	X	X	(FH) <i>Future use</i>

### External clock

When HEX-switch is on position 0, the clock extracted from the signal received at the E1 BNC Rx port is used. This is the normal configuration when connected to a telecom network.

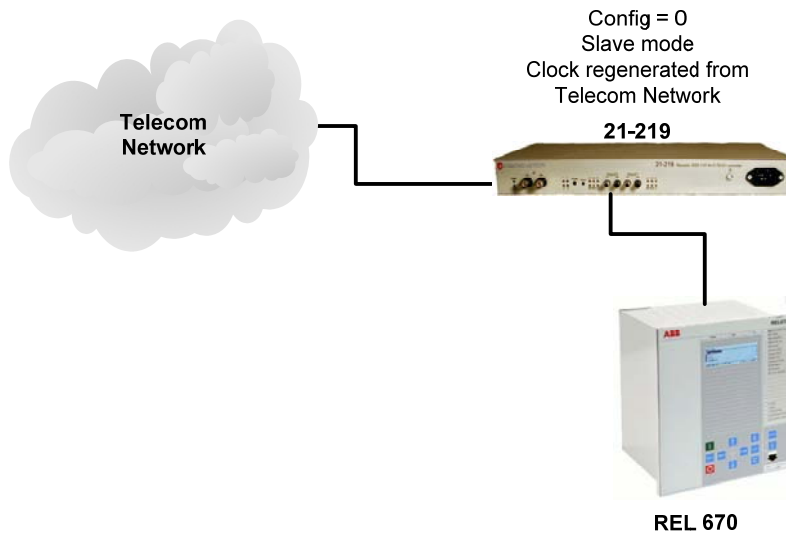

### Internal clock - "Master mode"

When HEX-switch is on position 1, the clock used is generated by an internal 2048kHz clock. This is used when two 21-219 are directly connected to each other with coaxial cables. Only one 21-219 shall have this configuration.

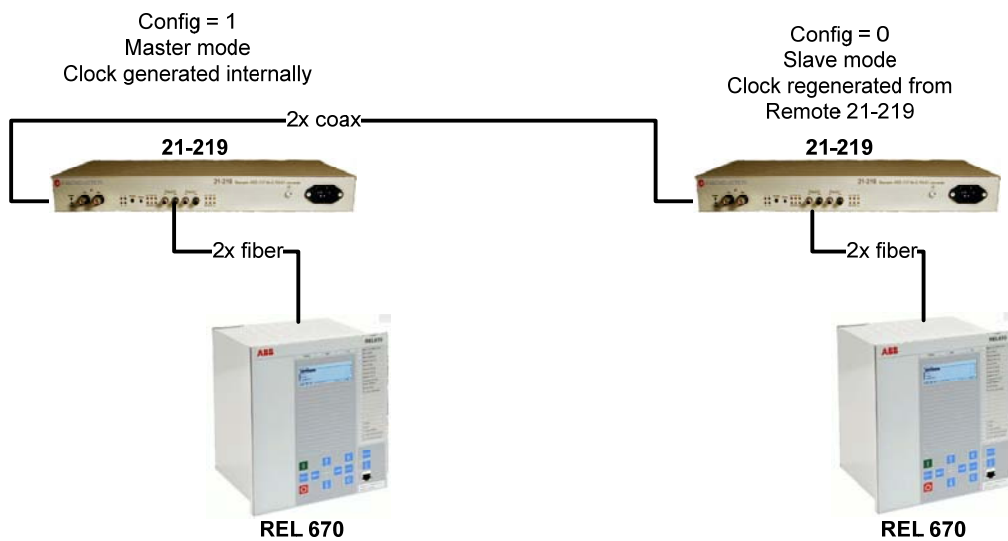

# Start and usage.

Power on.

Connect the power cord to the 21-219 and then connect to mains.

LED-status.

There are 18 LED-indicators at the front panel.

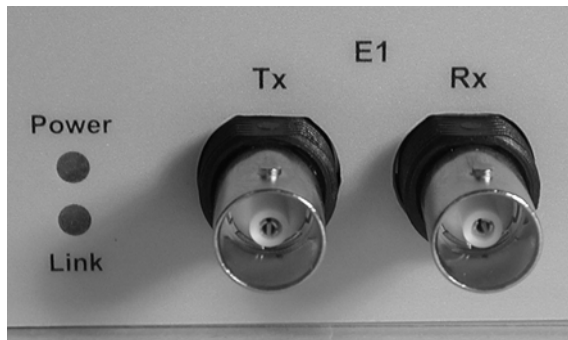
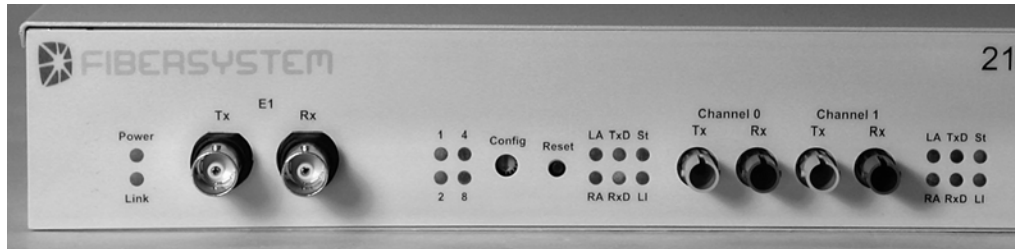

## Power

A green LED lit when power is connected to the unit.

## Link

A green LED lit when E1-frames, (PCM31 or PCM31C), are received and accepted on BNC-port Rx. If “Yellow bit” is set in E1-frame or if AIS-condition on received frame, the Link-LED will blink.

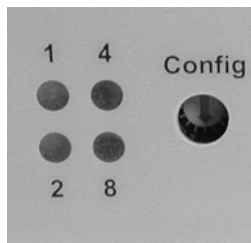

## 1, 2, 4, 8

Yellow LEDs. Marks the position of the Config switch. The four LEDs forms a binary value, lit LEDs, corresponding to the 16 positions of the Config switch. Only position 0 and 1 of the configuration switch are used. LEDs 2, 4 and 8 shall always be “black”.

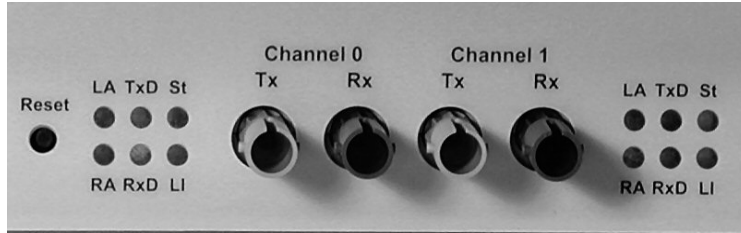

The LEDs to the left of fiber optic ports are indicators for “Channel 0”.  
 The LEDs to the right of fiber optic ports are indicators for “Channel 1”.

**LA**

Local Alarm. A red LED indicating that the 21-219 has encounter a fault in the received IEEE C37.94 protocol – LOS Loss Of Signal. The “Yellow Alarm bit” is set in the outgoing IEEE C37.94 protocol.

Is red when the 21-219 has detected an error. This indication has a memory function. When the local-error is no longer present, the LA-LED will be blink until “Reset”-button is pressed.

**RA**

Remote Alarm. A red LED indicating that the remote unit has encounter a fault condition and has set the “Yellow Alarm bit” in the IEEE C37.94 protocol.

Is red when the remote unit of the fiber optic link has detected an error. This indication has a memory function. When the remote-error is no longer present, the RA-LED will be blink until “Reset”-button is pressed.

**St**

Status. A red LED is lit when the 21-219 has set outgoing data on fiber to AIS-condition

**LI**

Link Fiber. A green LED indicating that the 21-219 receives correct IEEE C37.94 frames, (no LOS). Blinks when fiber optic receiver indicate low signal amplitude. Low amplitude is indicated when received optical signal power is between -35dBm and -40dBm.

The IEEE C37.94 standard specifies: *“The receiver shall operate error-free (BER < 1E -9) for mean optical power between -32 dBm and -11 dBm.”*

**TxD**

Received data from E1 sent out to IEEE C37.94. A yellow LED indicating that 21-219 sends data in IEEE C37.94 format.

**RxD**

Receive IEEE C37.94 data on fiber. A yellow LED indicating that 21-219 receives data in IEEE C37.94 protocol.

# Technical support

Before contacting technical support, we beg you to first read the manual once again..  
If you still have problems or questions, don't hesitate to contact help desk. Please gather all relevant information, including serial number, about your installation before contacting help desk.

Our technical support can be reached at:

Fibersystem AB

Gardsfogdevagen 18B

S-16866 Bromma

Sweden

Telephone: +46-8-564 828 80 • telefax: +46-8-28 33 50

Web: <http://www.fibersystem.se/>

E-mail addresses can be found on our web-site.

## CE - mark

The product described in this manual, is designed to apply to the specifications of the EMC directive 89/336/EEC and to low voltage directive 73/23/EEC

-:-